



Seri-Para I/O Unit for outdoor unit (CZ-CAPDC2) INSTALLATION INSTRUCTIONS

Procedures and Technical Points for Test Run

Warnings and Cautions

The precautions given in this manual consist of specific “Warnings” and “Cautions.” They provide important safety-related information and are important for your safety, the safety of others, and trouble-free operation of the system. Be sure to strictly observe all safety procedures. The labels and their meanings are as described below.

 **Warning** This symbol refers to a hazard or unsafe procedure or practice which can result in severe personal injury or death.

 **Caution** This symbol refers to a hazard or unsafe procedure or practice which can result in personal injury or product or property damage.

* After installation is completed, perform a test run to check for operating trouble. As you do, use the central control device Operation Manual and explain operating procedures to the customer. Then request that the customer store the Procedures and Technical Points for Installation of LonWorks Interface (Electrical Work) together with the central control device Operation Manual.

Warning

* Be sure to arrange installation from the dealer where the system was purchased or using a professional installer. Electric shock or fire may result if an inexperienced person performs any installation or wiring procedures incorrectly.

*Only a qualified electrician should attempt to connect this system, in accordance with the instructions in “technical standards related to electrical design,” “local wiring regulations,” and this manual. Electric shock or fire may result if electrical work is not correctly done.

ELECTRICAL WIRING REQUIREMENTS

Precautions regarding electrical wiring

*Use a dedicated electrical circuit. If the electrical circuit capacity is insufficient a danger of electric shock and fire may be present.

*Use the specified cables (type and wiring diameter) for the electrical connections, and connect the cables securely. Run and fasten the cables securely so that external forces or pressure placed on the cables will not be transmitted to the connection terminals. Overheating or fire may result if connections or attachments are not secure.

*The installation location requires the use of a circuit breaker. Failure to use a circuit breaker may result in electric shock or fire.

*Circuit breaker must be incorporated in the fixed wiring in accordance with the wiring regulations. The circuit breaker must be an approved 10-16 A, having a contact separation in all poles.

1. Installing the Seri-Para I/O Unit for outdoor unit

- <Note 1> Do not run the inter-unit control wiring, input/output lines, and power cables through the same conduit, or place the cables near one another. Doing so can cause malfunction.
- <Note 2> Install the Seri-Para I/O Unit for outdoor unit away from any sources of electrical noise.
- <Note 3> Avoid installing in any locations where the interface may come into contact with water, in locations where water accumulates, or in any extremely humid locations.
- <Note 4> Avoid installing in any location that is subject to excessive vibration or physical impacts.

Note that when the Seri-Para I/O Unit for outdoor unit is used incorporated in the control panel, it is necessary to make local procurement of the control panel that can accommodate required number of the Seri-Para I/O Unit for outdoor unit.

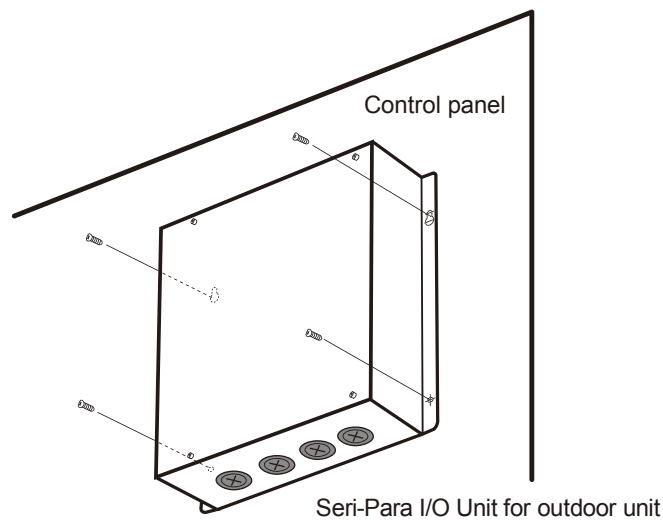

2. Wiring for the Seri-Para I/O Unit for outdoor unit

For safety, turn off the main power supply (breaker) before installing or removing the Seri-Para I/O Unit for outdoor unit.

Remove the 4 screws from the body and remove the top cover.

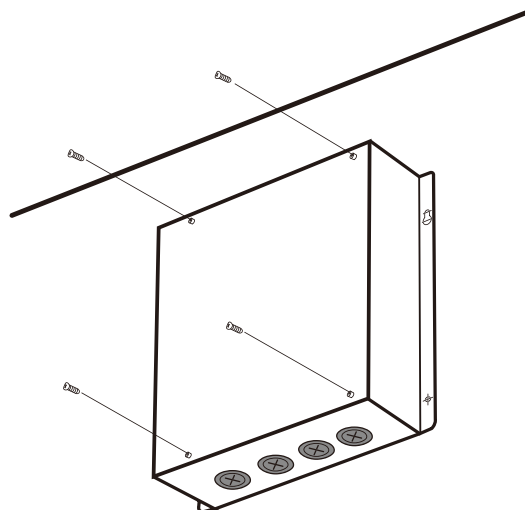

<Arrangement of components on the Seri-Para I/O Unit for outdoor unit board>

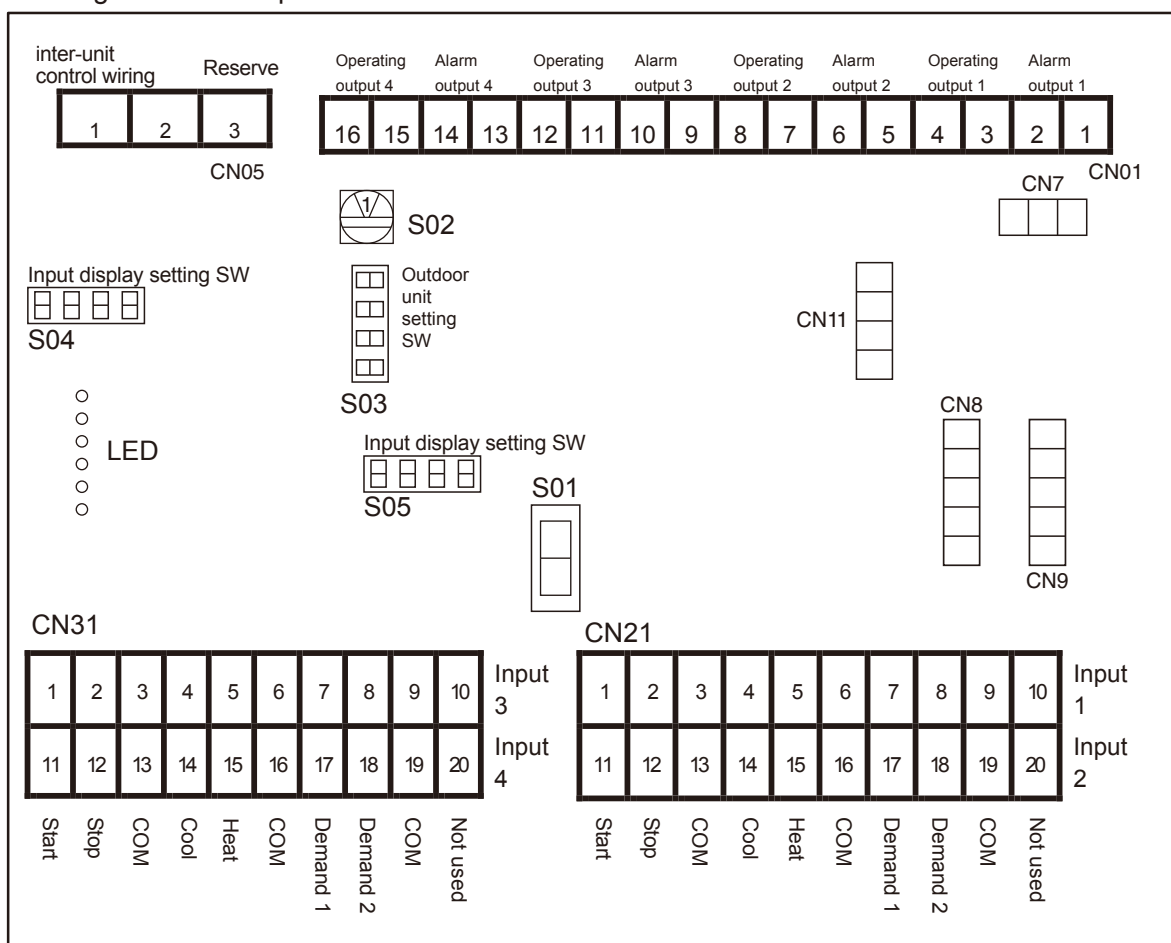

(1) Connecting the power

This interface can use either 110-120V AC power or 220-240V AC power. Insert the transformer primary-side (red 5P connector) into either the 110-120V AC CN (red connector labeled "CN 9") or the 220-240V AC CN (red connector labeled "CN8") on the circuit board. Check the power voltage that will be used before changing it. It is initially set for 220-240V AC power.

Caution

- Be careful: If the combination of the power voltage and the transformer primary-side selection is incorrect, the interface may be damaged.
- Turn the power off before changing the connector.
- This is a high-voltage circuit, and there is danger of electric shock. Do not touch the circuit when the power is on.
- Do not touch the power connector or any other protruding metal parts when the power is on.
- Turn the power on again when a defective communication or a malfunction is generated.

<Arrangement of transformer, power connector, and terminal block>

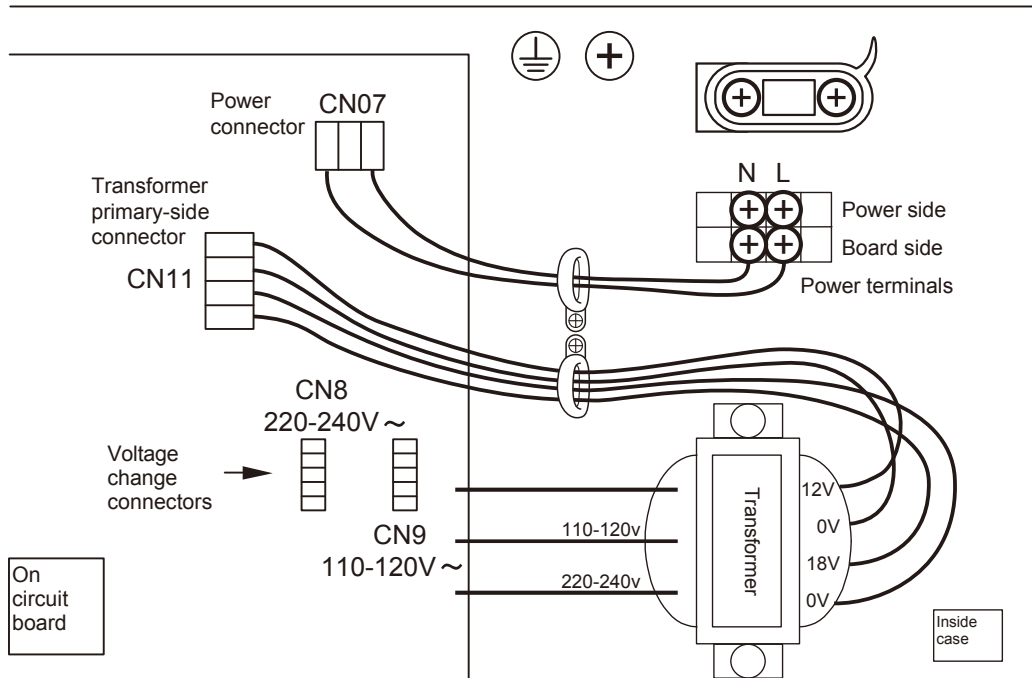

Changing the voltage:

- For 110-120V AC specifications, connect the 5P connector from the transformer to the 110-120V AC side, as shown in the figure below. (Because of the danger of electric shock, turn the power off before changing the connector.)

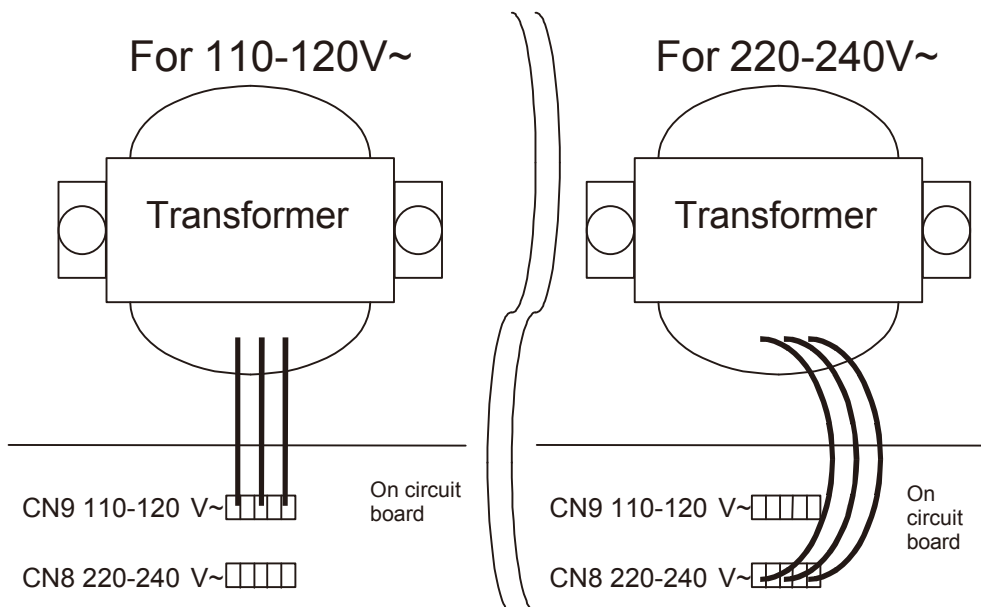

<Wiring Procedure>

- Connect the power supply lines to the L and N power supply terminals (the power supply neutral to the N terminal.)
- Connect an earth ground line to the screw.

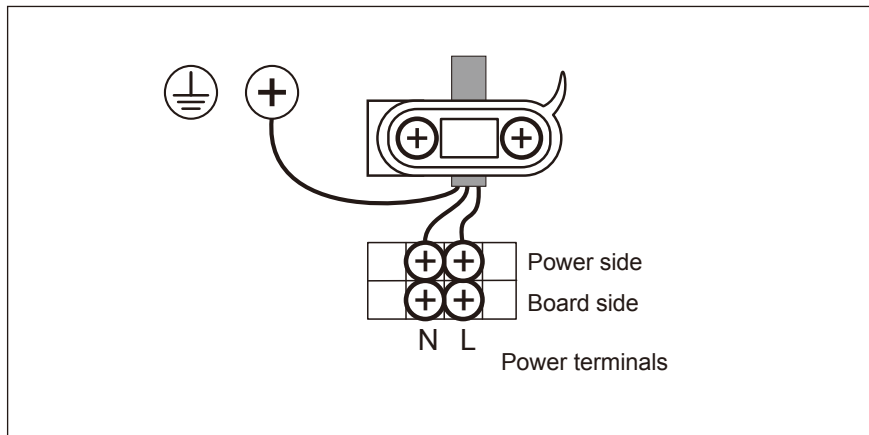

(2) Connecting the Seri-Para I/O Unit for outdoor unit and the inter-unit control wiring

- Use the inter-unit control wiring to connect the Seri-Para I/O Unit for outdoor unit to the A/C units.
- For the inter-unit control wiring, use twin-core 0.5– 2 mm² wires and shielded wiring. (Maximum length 1km.) There is no polarity to the signal wires.

Do not use the same cable for the inter-unit control wiring and power cables. Do not run them through the same conduit or place the cables near one another. For the inter-unit control wiring, use signal wires that are clearly differentiated from the power cables.

<Signal wire type> Thickness: 0.5 – 2.0 mm²

- CCV Vinyl-insulated vinyl-sheath control cable
- VCTF Vinyl cabtyre round cable
- VCT 600V vinyl cabtyre cable
- VVR Vinyl-insulated vinyl-sheath round cable
- MVVS Braided shielded instrumentation cable
- CPEVS Shielded polyethylene-insulated vinyl-sheath cable

<Wiring procedure>

- Inter-unit control wiring (Use the shielded wiring)
- Connect the inter-unit control wiring connector terminals for the indoor or outdoor unit to CN05 1 and 2 on the board's inter-unit control wiring terminal block (for communications).

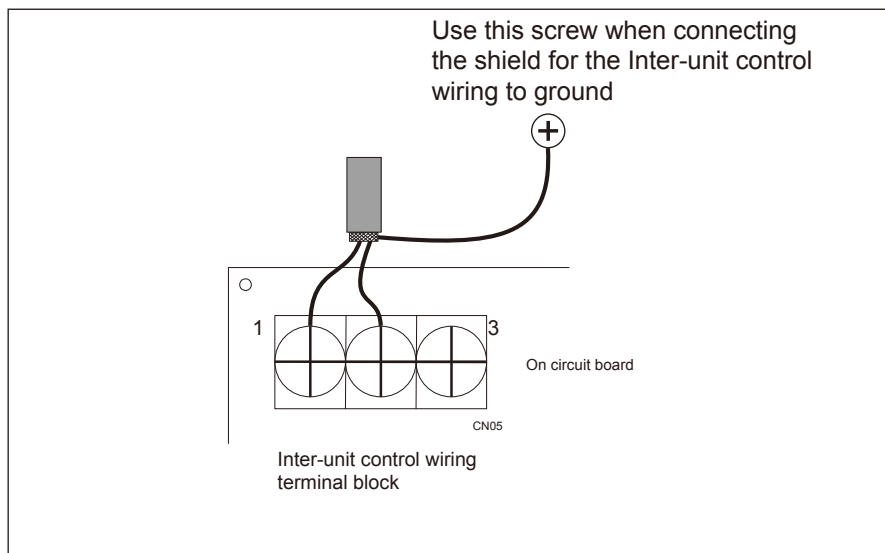
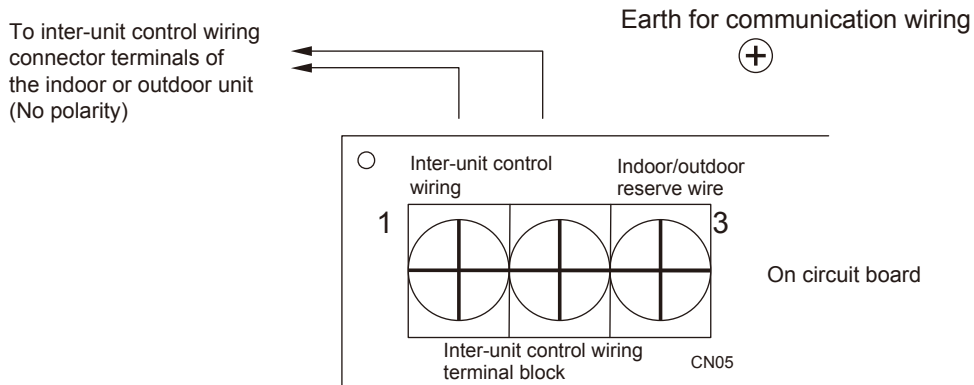

Check that the power cable (110-120/220-240V AC) has not been wired to the inter-unit control wiring terminal block. If power is accidentally applied here, the board fuse (F01) will blow in order to protect the circuit board. After correcting the power cable connection, wire by connecting the inter-unit control wiring to CN05 1 to 3 (using the indoor/outdoor reserve wire).







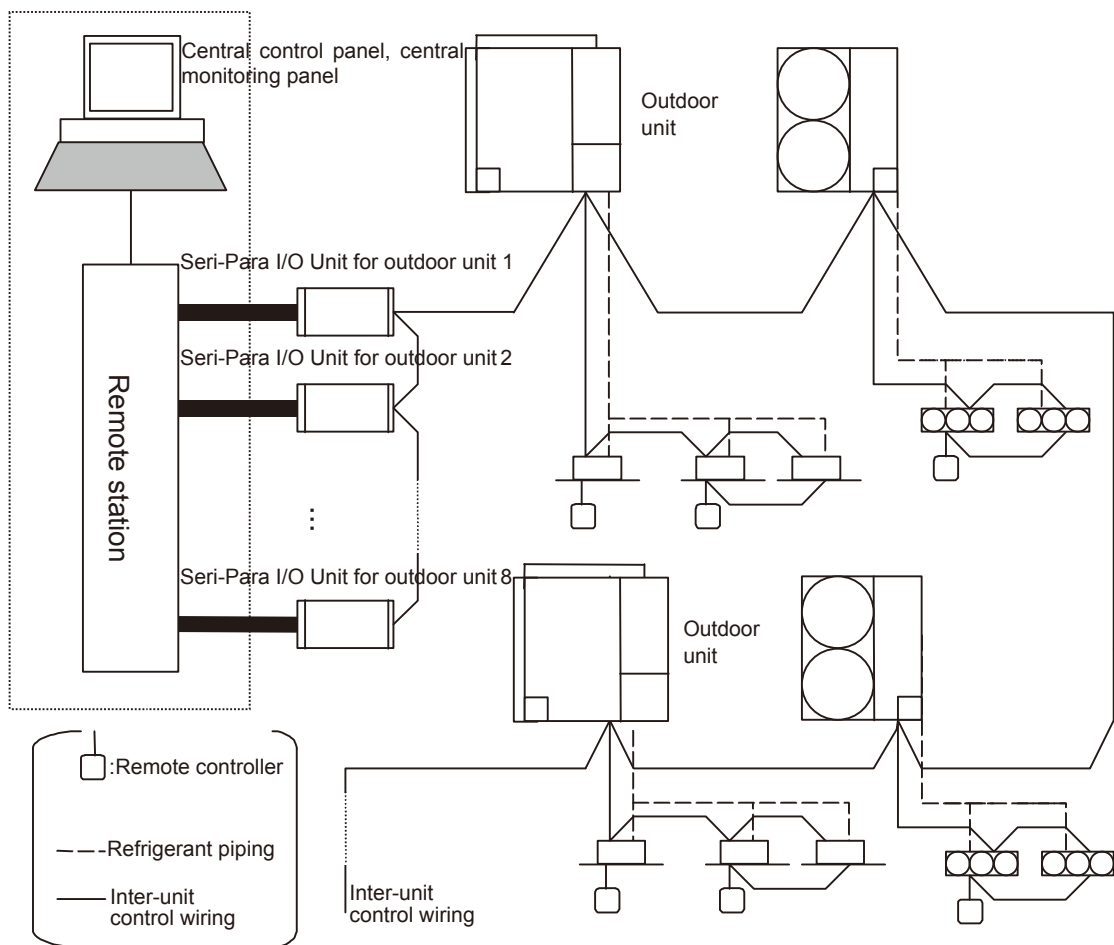





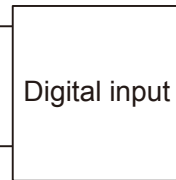



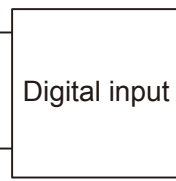

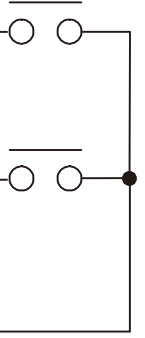

(Be sure to turn the power off before beginning work.)

<Basic wiring diagram>

- The diagram below shows a sample wiring arrangement of inter-unit control wiring for the Seri-Para I/O Unit for outdoor unit.
- One system can include a maximum of 30 connected outdoor units and 64 connected indoor units.
- One Seri-Para I/O Unit for outdoor unit can be connected to a maximum of 4 outdoor units in 1 system. A maximum of 8 Seri-Para I/O Unit for outdoor units can be connected to control up to 30 outdoor units.

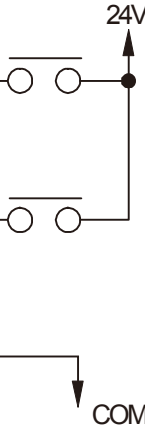

(3) Connections between the Seri-Para I/O Unit for outdoor unit and external connectors(central control panel, central monitoring panel)

Name	Input/output item	Seri-Para I/O Unit for outdoor unit side		Equipment (central control panel, central monitoring panel) side		
		Input/output condition	Terminal No.	Separation terminal	Sample circuit	Input/output condition
Contact input/output terminal	Status output	Operating output 1 - 4 No-voltage a-contact output Allowable contact voltage and current: 30 V, 1 A Minimum applied load: 1V, 1 mA	CN01-3,01-7,  CN01-11,01-15			Response time for start/stop input: Max. 20 s
		CN01-4,01-8,  CN01-12,01-16				
	Alarm output 1 - 4 No-voltage a-contact output Allowable contact voltage and current: 30 V, 1 A Minimum applied load: 1V, 1 mA	CN01-1,01-5,  CN01-9,01-13			Response time for start/stop input: Max. 20 s	
		CN01-2,01-6,  CN01-10,01-14				
Control input	All-start input (pulse/static) Photocoupler input Allowable contact voltage and current: DC 24V, 10 mA Switch 01 is set as a no-voltage contact (setting when unit is shipped).	CN21-1,21-11,  CN31-1,31-11			Pulse width: 1 s or more No-voltage a-contact output	
	CN21-2,21-12,  CN31-2,31-12					
CN21-3,21-13,  CN31-3,31-13						
Control input	All-start input All-stop input (pulse/static) Photocoupler input Allowable contact voltage and current: DC 24 V, 10 mA Switch 01 is set as DC 24 V contact.	CN21-1,21-11,  CN31-1,31-11			Pulse width: 1 s or more No-voltage a-contact output	
	CN21-2,21-12,  CN31-2,31-12					
	CN21-3,21-13,  CN31-3,31-13					

Name	Input/output item	Seri-Para I/O Unit for outdoor unit side		Equipment (central control panel, central monitoring panel) side		
		Input/output	Terminal No.	Separation terminal	Sample circuit	Input/output condition
Contact input/output terminal	Control input (static)	Cool input Heat input (Demand 1, demand 2) Photocoupler input Allowable contact voltage and current: DC 24 V, 10 mA Switch 01 is set as a no-voltage contact (setting when unit is shipped).	CN21-4,21-14, (21-7,21-17) CN31-4,31-14, (31-7,31-17) CN21-5,21-15, (21-8,21-18) CN31-5,31-15, (31-8,31-18) CN21-6,21-16, (21-9,21-19) CN31-6,31-16, (31-9,31-19)			Pulse width: 1 s or more No-voltage a-contact output
	Control input (dynamic)	Cool input Heat input (Demand 1, demand 2) Photocoupler input Allowable contact voltage and current: DC 24 V, 10 mA Switch 01 is set as DC 24 V contact.	CN21-4,21-14, (21-7,21-17) CN31-4,31-14, (31-7,31-17) CN21-5,21-15, (21-8,21-18) CN31-5,31-15, (31-8,31-18) CN21-6,21-16, (21-9,21-19) CN31-6,31-16, (31-9,31-19)			Pulse width: 1 s or more No- voltage a-contact output

Note: Demand 1 and 2 (shown in parentheses) are listed together because their structure is the same as cool/heat input.

- The length of digital signal wiring between the Seri-Para I/O Unit for outdoor unit and the equipment side must be 100 m or less.

* Input terminal block table

	Input 1	Input 2	Input 3	Input 4
All-start	CN21-1 CN21-3	CN21-11 CN21-13	CN31-1 CN31-3	CN31-11 CN31-13
All-stop	CN21-2 CN21-3	CN21-12 CN21-13	CN31-2 CN31-3	CN31-12 CN31-13
Cool	CN21-4 CN21-6	CN21-14 CN21-16	CN31-4 CN31-6	CN31-14 CN31-16
Heat	CN21-5 CN21-6	CN21-15 CN21-16	CN31-5 CN31-6	CN31-15 CN31-16
Demand 1/ thermostat OFF	CN21-7 CN21-9	CN21-17 CN21-19	CN31-7 CN31-9	CN31-17 CN31-19
Demand 2/ remote-con- troller inhibit	CN21-8 CN21-9	CN21-18 CN21-19	CN31-8 CN31-9	CN31-18 CN31-19

* Polarity for input wiring

	Input (start, stop, cool, heat, demand 1/thermostat OFF demand 2/remote-controller inhibit)	COM
S01-direction no-voltage contact	Because it is a no-voltage contact, there is no polarity.	Because it is a no-voltage contact, there is no polarity.
S01-direction DC 24 V contact	Positive	COM

3. Setting Switches

- Setting switch S01 (Change the voltage before turning on the power.)

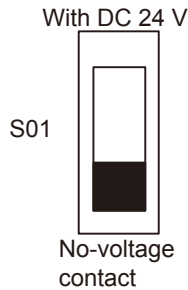

- S01 (contact input voltage change SW) (Set as a no-voltage contact when unit is shipped.)
 1. When using the input terminal as a no-voltage a-contact, set switch S01 to the no-voltage contact side.
 2. When using the input terminal as a DC 24 V contact, set switch S01 to the DC 24 V voltage side.

- Setting switches S02 and S03

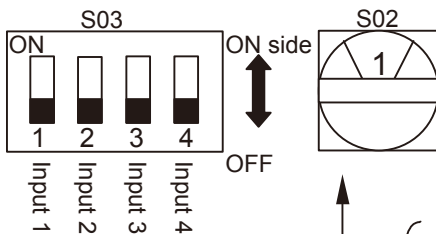

- S02 (outdoor SP address setting SW) This switch sets the Seri-Para I/O Unit for outdoor unit address. (Refer to *1.)
- S03 (outdoor unit setting SW) This switch sets the connected outdoor units. Be sure to turn the SW to the ON side for each input that will be used. (Note: If input is turned OFF, no input or output occurs.)

- 1: Outdoor unit addresses 1 - 4 2: Outdoor unit addresses 5 - 8
 - 3: Outdoor unit addresses 9 - 12 4: Outdoor unit addresses 13 - 16
 - 5: Outdoor unit addresses 17 - 20 6: Outdoor unit addresses 21 - 24
 - 7: Outdoor unit addresses 25 - 28 8: Outdoor unit addresses 29 - 30
- (0 is set the same as 1. 9 is set the same as 8.)

(*1) Relationship between the input/output terminal block (input/output 1 - 4) and the Outdoor unit address when S02 (outdoor SP address setting SW) is changed

S02 (outdoor SP address setting SW)	Input/output terminal block number				System address (outdoor unit address)
	1	2	3	4	
1	1	2	3	4	
2	5	6	7	8	
3	9	10	11	12	
4	13	14	15	16	
5	17	18	19	20	
6	21	22	23	24	
7	25	26	27	28	
8	29	30	30	30	

* Set the S02 not to overlap.

- Setting switch S04

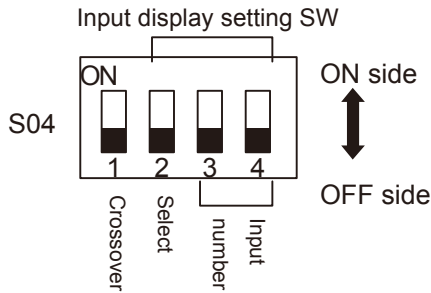

- S04-1 (OFF when unit is shipped.)

Crossover	OFF	No crossover process (normal)
	ON	Crossover process performed (Connect only to terminal block input 1.)

* Crossover process: Performs the same process as if terminal block inputs 1 - 4 were wired across one another. (Processing proceeds as if inputs 2 - 4 were the same as input 1.) Even if there is crossover input, input and output operations are not performed if the S03 input is turned OFF.

- S04-2 (OFF when unit is shipped.)

Select	OFF	Displays the status of communications with the outdoor unit corresponding to LED 1 - 4.
	ON	Using the LED (6), displays the input status (start, stop, etc.) for the terminal block with the input number selected.

- S04-3 and 4 input number selection: Select the input number to check.

	S04-3	S04-4
Input 1	OFF	OFF
Input 2	OFF	ON
Input 3	ON	OFF
Input 4	ON	ON

* The following information is displayed by the LED, according to the settings of S04-2 (select) and S04-3 and 4 (input number).

(If the select switch is ON, the LED illuminate according to the signal that is being input at the input terminal block with the selected number.)

Select	OFF (normal)	ON (for checking input)
LED explanation	1 ○	Start ○ Input present: Lit Stop ○ No input: Not lit Cool ○ Heat ○ Demand 1 ○ Demand 2 ○
	2 ○	
	3 ○	
	4 ○	
	○	
	○	
	○	
	○	
	○	
	○	
	○	
	○	

Note: If S04-2 (select) is ON, there are cases when communications errors may go unnoticed. Therefore, leave this switch OFF when checking normal communications.

- Setting switch S05

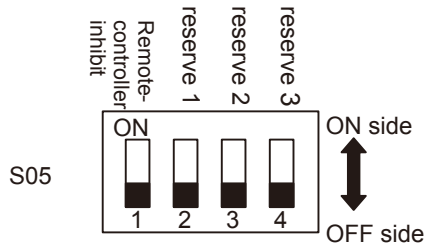

- S05-1 (OFF when unit is shipped.)
Changes the remote-controller inhibit switch input as shown below.

Remote-controller prohibit	OFF	Demand 1/demand 2
	ON	Thermostat OFF (*1)/remote-controller inhibit

*1 This input forces the thermostat to turn OFF (100% demand).

4. Detailed Explanation of Address Setting SW (S02)

The Seri-Para I/O Unit for outdoor unit addresses must be set (S02) when connecting and using multiple Seri-Para I/O Unit for outdoor units.

* The example here shows 8 Seri-Para I/O Unit for outdoor units and 30 outdoor units connected.

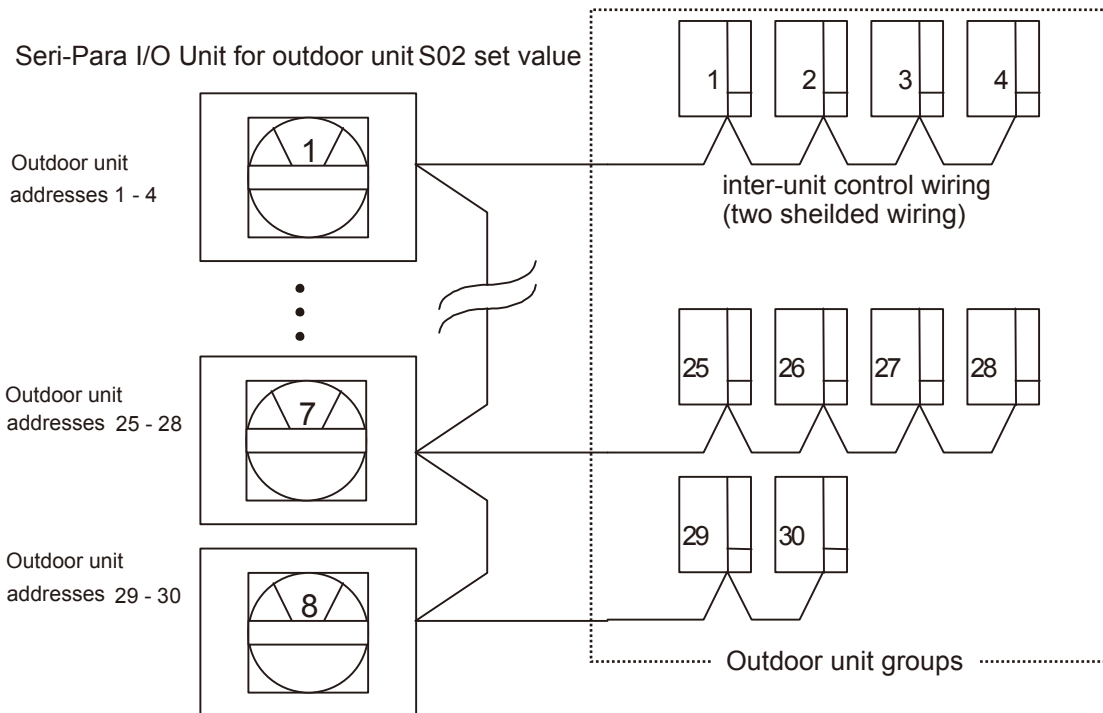

5. Test Run

1. Turn on the power to all A/C. Check that all test-runs are completed.
 2. After the A/C test-runs are completed, follow the procedure below.
 3. Turn on the power to the Seri-Para I/O Unit for outdoor unit. (Complete settings before turning on the power.)
 4. If there is no trouble with communications between the Seri-Para I/O Unit for outdoor unit and the outdoor units, then generate all-start input from the Seri-Para I/O Unit for outdoor unit. (Connect "Start" and "COM" on the input terminal block.) Check the operating lamps. Check all inputs in the same way. To check inputs, set the input number that you wish to check with settings switches S04-3 and 4 (input number switches). Then switch S04-2 (select switch) to ON and check the input. (Refer to **3. Setting Switches.**)
- Approximately 3 minutes after trouble occurs in the communications between the Seri-Para I/O Unit for outdoor unit and the outdoor units, the communications-check LEDs will begin flashing. When these LEDs are flashing, check and correct the communications line connections and power for the outdoor units which correspond to the flashing LEDs.

6. External Dimensions

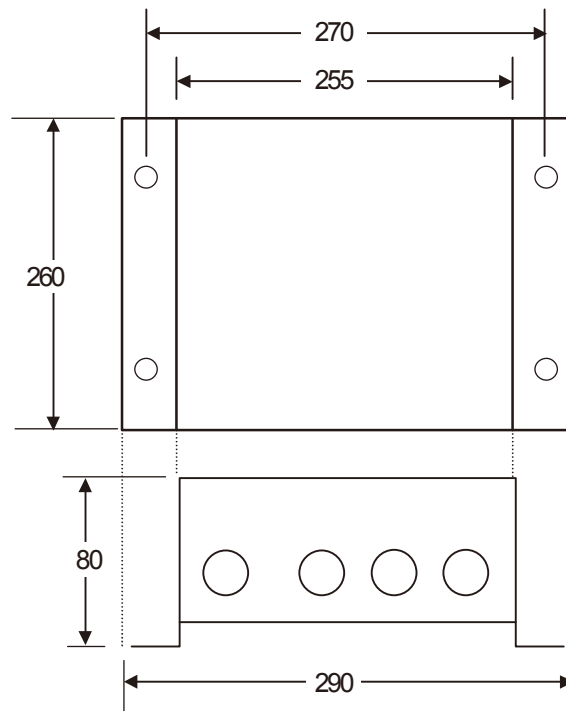

H80 x W290 x D260 mm

7. Product Specifications

Specifications

Rated voltage:	Single-phase 110-120 / 220-240 V ~
Rated frequency:	50-60 Hz
Power consumption:	Approx. 18 W
Weight:	3.2 kg

